

February 2023

Description

Moore Industries' universal TDY PC-Programmable Temperature Transmitter features a large integral display that shows real-time process status and valuable loop diagnostic information. Combining smart digital technology with advanced analog operation, the TDY delivers superior reliability, accuracy and ease of use.

The 2-wire (loop-powered) TDY programs in a minute or less to accept direct inputs from:

- **22 RTD Types**
(2, 3, or 4-wire; Pt, Cu, or Ni; 10 to 1000 ohms)
- **9 Thermocouple Types**
(J, K, E, T, R, S, B, N and C)
- **Direct Millivolt Sources**
(-50 to 1000mV)
- **Resistance & Potentiometer Devices**
(0 to 4000 ohms)

The TDY converts the input to an accurate 4-20mA output that is both linear and input scalable-ready to interface to readout instruments, recorders, DCS units and other computer-based SCADA systems.

Figure 1. Our ready-to-install TDY temperature assemblies include your choice of enclosure, sensor, thermowell and fittings in one easy-to-order package.



Available in a variety of mounting styles, the TDY installs quickly and easily on a pipe or surface in the field, or on DIN rail and relay track in an multi-unit enclosure or cabinet.

Features

- **Exceptional accuracy.** The TDY provides the highest accuracy (up to $\pm 0.05^{\circ}\text{C}$) for your critical process applications.
- **Easy-to-read, customizable display.** The TDY's large display features alphanumeric characters that can be read easily in the field. It can be customized to display the input, output, or toggle between both.
- **Auto decimal point.** The TDY makes the most of its display area by automatically adjusting the decimal point in response to the number of digits required to represent the process variable being measured.
- **Sets up in a minute or less.** The ideal universal plant standard, our TDY offers dozens of input, output, and operation choices, and still configures fast from a single software window.
- **Fast measurement cycle.** Delivering output updates at least 8 times per second, these transmitters are twice as fast as comparable microprocessor-based instruments.

Certifications



TDY

PC-Programmable
Temperature Transmitter with Display

Universal Solution

With the TDY, there's no need to specify and stock an array of single-function instruments:

- Simplify gathering information in the field or control room with its large, easy-to-read display.
- Convert RTD, T/C, mV, and Ohm signals to the linear 4-20mA needed by an indicator, recorder, PC, PLC, DCS, or similar SCADA system.
- Customize linearization to easily process inputs in non-linear, millivolt input applications.
- Stop ground loop problems with total isolation.
- Trim input readings directly from sensors to achieve maximum relative accuracy and match performance characteristics with your already-installed hardware.

- Convert signals from weak, low-level signals that allow inaccuracies from plant noise to stable, high-level signals that can withstand long-distance transmission through a noisy plant.
- Use true 4-wire RTD inputs to eliminate signal inaccuracies resulting from inevitable lead wire resistance imbalances.
- Increase DCS accuracy by using transmitters calibrated to a specific temperature range in place of direct DCS inputs that are only capable of measuring readings over the entire range of a sensor.
- Reduce installation costs by replacing expensive and fragile sensor wire runs and costly DCS input cards.
- Compensate for erratic input signals with programmable damping values.

Total Sensor Diagnostics

Our programmable transmitters perform continuous sensor diagnosis. This patented Moore Industries feature can save you from the costly problems of lost production time and hours of troubleshooting by identifying the type and location of the problem.

Monitors Sensor During Operation

If a RTD wire breaks or otherwise stops sending a signal during operation, the transmitter sends the output upscale or downscale (your choice) to warn of trouble.

The TDY instantly displays the type and location of the error. This helps you quickly diagnose the problem. If you do need additional help, our transmitters go even further! When the PC is connected to the TDY loop and an error occurs, the configuration software will display a detailed, plain-English error message.

Figure 2. Total Sensor Diagnostics saves troubleshooting time.

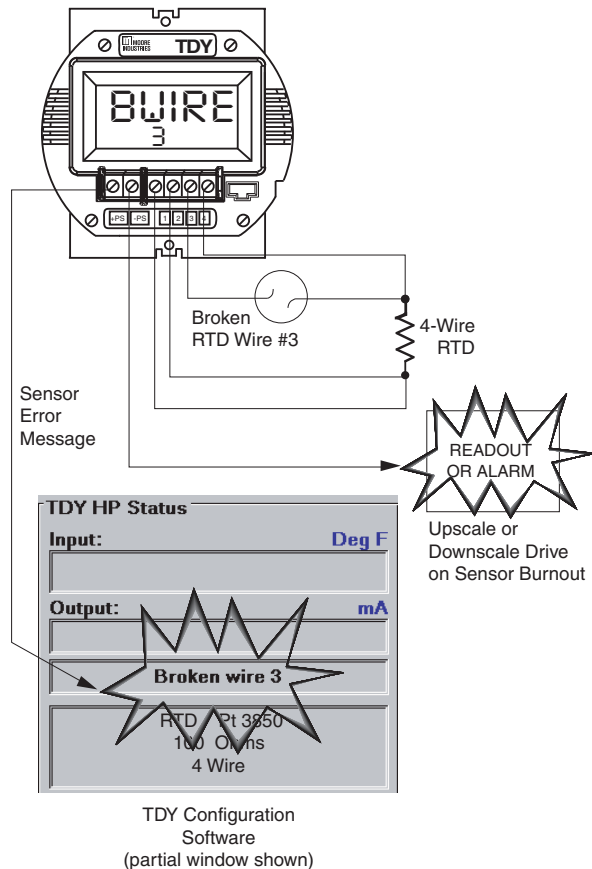

Intelligent Configuration Software

Configuring the TDY is as simple as point-and-click. Custom linearization and trimming capabilities make it an even more valuable tool.

All you need is a PC running Windows®, our TDY Configuration Software and a Configuration Cable (software supplied with each order).

In minutes, you can begin configuring your transmitter's:

- Display type and range (zero and full scale; mV, %, ohms, °F, or °C)
- Input type and range (zero and full scale)
- 4-20mA output range (zero and full scale)
- Reference junction compensation or no reference junction compensation for T/C inputs
- Linearization or no linearization for T/C inputs
- Sensor type
- 50Hz or 60Hz noise rejection
- Broken wire detection ON or OFF for calibration
- Upscale or downscale on sensor burnout
- Custom instrument tag (up to 40 characters)
- Custom input linearization (up to 85 points)
- Custom input trimming to actual sensors
- Loop test fixed output for easy calibration of other instruments in the loop
- Damping time for erratic signal compensation (0-5 seconds)

Figure 3. All operating parameters can be set, and then viewed, on a single software screen.

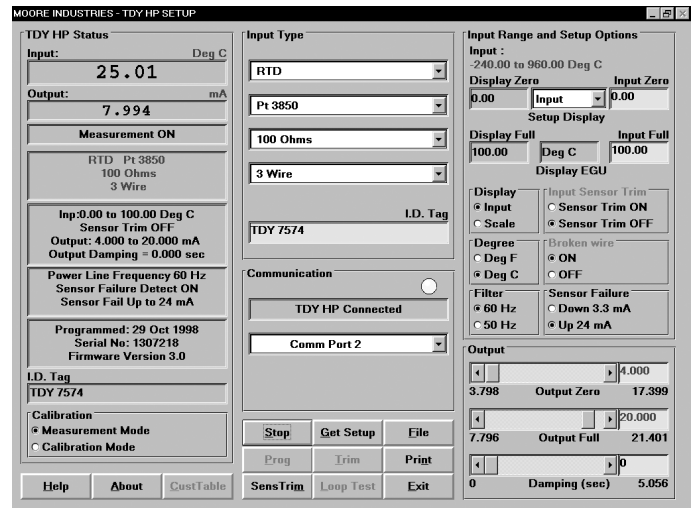

Digital Trimming Enhances Accuracy

A single click of the mouse “captures” the actual sensor input zero or full scale. Scaling values can be entered directly from the PC. Using the on-screen adjustments for output, Zero Scale can be set between 3.800 and 17.400mA. Full Scale can span from 7.800 to 21.400mA.

Precise Input Capturing

The TDY Configuration Software will capture the upper and lower range of the sensor with just a click of a mouse.

Custom Tables Ease Linearization Problems

Unusual inputs are no problem for the TDY. Not when it is so easy to use the Configuration Program’s straight-forward interface to build a custom, 85-point linearization table (mV input type only).

Output Damping Ensures Stable Output

If your sensor is prone to step increments and decrements, use the TDY to lessen the impact on your process. Program a damping value from 0 to 5 seconds, averaging out sensor fluctuations over time and lessening the impact of step changes.

Specifications

Performance Input Accuracy:
Refer to Table 2 for standard accuracy specifications.
Output Accuracy: 4.8µA (±0.03% of 4-20mA span)
Overall Accuracy:
Overall accuracy of the unit is the combined input and output accuracy. It includes the combined effects of linearity, hysteresis, repeatability and adjustment resolution. It does not include ambient temperature effect. For T/C input only, add the Reference Junction Compensation error.
Reference Junction Compensation Accuracy:
±0.45°C
Stability:
Error is in % of conformance range.

Stability	Input to Output		
	1yr	3yrs	5yrs
T/C, mV	0.11	0.18	0.24
RTD Ohm Pot.	0.13	0.22	0.28

Isolation:
500Vrms input to output to case
Measurement Cycle:
Output updates at least 8 times per second

Performance (Continued) Output Response:
256msec, typical, 300msec, maximum, for output to change from 10% to 90% of its scale for an input step change of 0% to 100%.
Ripple: ≤10mVp-p, maximum
Power Supply and Load Effect: Negligible within power and load limits
Over-Voltage Protection: 4V maximum, on input; 48V maximum, on output; 48V reverse polarity protection on output
Output Current Limiting: 3.8mA and 21.4mA for input over/under range; 25mA maximum (hardware limit)
Load Capability: 583 ohms@24V, typical; Supply Voltage - 10V / 0.024A = Ohms
Burnout Protection:
Total Sensor Diagnostics are user-selected via Windows®-based configuration software; Upscale to 23.6mA or Downscale to 3.6mA
T/C Input Impedance: 40 Mohms, nominal
RTD Excitation: 250 microamps, ±10%
RTD Lead Wire Resistance Maximum: RTD resistance + 2 times the lead wire resistance must be less than 4000 ohms; recommended <35 ohms per wire for 3-wire inputs; <5 ohms per wire for 10 ohm Cu inputs

Display Type: LCD; Top Row, 10.16mm (0.4 in) high black digits on a reflective background; Bottom Row, 5.72mm (0.225 in) high black digits on a reflective background
Format: Two rows of five alphanumeric characters
Decimal Points: Automatically adjusting decimal point with a two decimal place maximum (Analog output display is always two decimal places)
Range: -99999 to 99999
Minimum Display Span: 1.00

Ambient Operating and Storage Conditions Range:
-40°C to 85°C (-40°F to 185°F)
Relative Humidity: 0-95%, non-condensing
Effect of Ambient Temperature on Accuracy:
±0.015% of span per °C change, maximum (+0.001% of resistance reading for RTD inputs)
Effect of Ambient Temperature on Reference Junction Compensation:
±0.015°C/°C change
RFI/EMI Immunity: 20V/m@80-1000MHz, 1kHz AM, when tested according to IEC 61326
Common Mode Rejection: 100dB min. @ 50/60Hz
Normal Mode Rejection: Refer to Table 1

Adjustments All settings made using our Windows®-based configuration program, then stored in non-volatile memory

Weight HP housing: 178g (6.3 oz)
BH housing: 1.5 kg (3.3 lbs)
D2LC housing: 688g (1 lb, 8.3 oz)

Table 1. Normal Mode Rejection Ratio Table

Sensor Type		Max. p-p Voltage Injection for 70dB at 50/60Hz
T/C: J, K, N, C, E		150mV
T/C: T, R, S, B		80mV
Pt RTD: 100, 200, 300 ohms		200mV
Pt RTD: 400, 500, 1000 ohms		800mV
Ni: 120 ohms		150mV
Cu: 9.03 ohms		100mV
Resistance	mV	
1-4kohms	250-1000	800mV
0.25-1kohms	62.5-250	200mV
0.125-0.25kohms	31.25-62.5	100mV

Ordering Information

Unit	Input	Output	Power	Options	Housings
TDY PC- Program- mable Temperature Transmitter with Display	PRG Programmable with supplied Configuration Software (see Table 1 for descriptions of available input types; factory configuration available)	4-20MA User scalable with supplied software	10-42DC 10-30DC for -IS option	-IS Option (cFMus, ATEX and IECEX Intri- nically Safe approval)	BH2NG (*) or (‡) Aluminum 2-Hub, Explosion-Proof enclosure with glass cover BH3NG (*) or (‡) Aluminum 3-Hub, Explosion-Proof enclosure with glass cover D1LC 1-Hub, low base, clear cover, NEMA 4X (IP66) enclosure D2LC 2-Hub, low base, clear cover, NEMA 4X (IP66) enclosure HP Hockey-puck housing and spring clips DN Snap-in mounting for HP case on TS-32 DIN rail FL Mounting flanges on HP suitable for relay track or screw mounting SB2NG (*) or (‡) 316 Stainless Steel 2-Hub, Explosion-Proof enclosure with two 1/2-inch NPT entry ports and a glass cover SB2MG (*) or (‡) 316 Stainless Steel 2-Hub, Explosion-Proof enclosure with two M20 x 1.5 entry ports and a glass cover

* Either A or E suffix (comes supplied with 2" pipe mount hardware)
 A suffix indicates ANZEx/TestSafe (Ex d)
 Flameproof approvals (i.e. BH2MGA)
 E suffix indicates ATEX (Ex d and tb) Flameproof approvals (i.e. BH2MGE)
 ‡ P suffix indicates enclosure comes equipped with base plate and U-bolts for mounting on a 2-inch pipe (i.e. BH2NGP)
 See BH, SB and D-BOX Datasheets for additional information.

To order, specify: Unit / Input / Output / Power / Option [Housing]
Model Number Example: TDY / PRG / 4-20MA / 10-42DC / -IS [BH2NG]

Complete Temperature Assemblies

Free yourself from the hassle of looking around for pieces and parts by ordering a complete assembly with just one order number. To complement our high-quality transmitters, we carry complete lines of RTDs, thermocouples, thermowells, connection heads and fittings. For accuracy as high as $\pm 0.05^{\circ}\text{C}$, have your TDY and sensor calibrated together in our sensor-matching calibration bath.

Sensor-to-Transmitter Matching

The sensor matching process starts by immersing the temperature sensor into stabilized temperature baths. The TDY captures two points from the sensor and stores them in non-volatile memory. It then uses them to compensate for deviations between a sensor's stated linearization curve and its actual measurements. Sensor matching provides you with incredible accuracy at an affordable price. Accuracy varies with the sensor, so contact the factory for information on your sensor type.

Accessories

Each TDY order comes with one copy of our Configuration Software. Use the chart below to order additional parts.

Part Number	Part
750-75E05-01	Intelligent PC Configuration Software
803-039-26	Isolated Configuration Cable
803-040-26	Non-Isolated Configuration Cable
804-030-26	Fuse Protected USB Communication Cable (required by IECEx and ATEX for products installed in Intrinsically-Safe areas)

Certifications



TDY-HP

Factory Mutual Approvals:

Intrinsically-Safe

Class I, Division 1, Groups A, B, C & D
 Class I, Zone 0, AEx ia IIC T4

Non-Incendive

Class I, Division 2, Groups A, B, C & D
 Class I, Zone 2, AEx nA IIC T4



ATEX Directive 2014/34/EU (FM Approvals):

Intrinsically-Safe and Type "n"

II 1 G Ex ia IIC T4 Ga
 II 3 G Ex nA IIC T4 Gc



IECEX System (FM Approvals):

Intrinsically-Safe and Type "n"

Ex ia IIC T4 Ga
 Ex nA IIC T4 Gc



CE Conformant – EMC Directive 2014/30/EU – EN 61326

Temperature Class T4, Tamb = -40°C to +85°C



TDY-HP in BH or SB2 Housing

Factory Mutual Approvals (FM Global Group):

Explosion-Proof & Dust-Ignition Proof

Class I, Division 1, Groups A*, B, C & D

Class II & III, Division 1, Groups E, F & G

Environmental Protection: NEMA 4X & IP66

T6 @ 60°C Maximum Operating Ambient

*For Group A applications, seal all conduits within 18"



CSA Group (Canadian Standards Association):

Explosion-Proof

Class I, Division 1, Groups A*, B, C, & D

Class II, III, Groups E, F, & G

Type 4X, IP66

Ambient Temp. Range: -20°C to +60°C; T6

*For U.S. Group A applications, seal all conduits within 18"



ATEX Directive 2014/34/EU (ISSEP):

Explosion-Proof/Flameproof

II G Ex d IIC T6 Gb

II D Ex tb IIIC Db T85°C IP66



ANZEx (TestSafe):

Explosion-Proof/Flameproof

Ex d IIC T6 (Tamb 60°C)

TDY

PC-Programmable Temperature Transmitter with Display

Table 2. TDY Input and Accuracy Table

Input	Type	α^*	Ohms	Conformance Range	Minimum Span	Input Accuracy	Maximum Range
RTD	Platinum	0.003750	1000	-50 to 500°C -58 to 932°F	15°C (27°F) for 100 ohms inputs 10°C (18°F) for 200 ohms inputs 7.5°C (13.5°F) for 500 and 1000 ohms inputs	±0.11°C ±0.2°F	-100 to 560°C -148 to 1040°F
		0.003850	100, 200, 300, 400, 500, 1000	-200 to 850°C -328 to 1562°F		±0.21°C ±0.38°F	-240 to 960°C -400 to 1760°F
		0.003902	100, 200, 400 500, 1000	-100 to 650°C -148 to 1202°F		±0.15°C ±0.27°F	-150 to 720°C -238 to 1328°F
		0.003911	100, 500	-200 to 630°C -328 to 1166°F		±0.17°C ±0.31°F	-235 to 710°C -391 to 1310°F
		0.003916	100	-200 to 510°C -328 to 950°F		±0.14°C ±0.25°F	-240 to 580°C -400 to 1076°F
		0.003923	98.129	-200 to 600°C -328 to 1112°F		±0.16°C ±0.29°F	-235 to 680°C -391 to 1256°F
		0.003926	100, 470, 500	-200 to 630°C -328 to 1166°F		±0.17°C ±0.31°F	-235 to 710°C -391 to 1310°F
		0.003928	100	-200 to 850°C -328 to 1562°F		±0.21°C ±0.38°F	-260 to 962°C -436 to 1763.6°F
	Nickel	0.000672	120	-80 to 320°C -112 to 608°F	10°C 18°F	±0.16°C ±0.29°F	-100 to 360°C -148 to 680°F
	Copper	0.000427	9.035	-50 to 250°C -58 to 482°F	100°C 180°F	±1.2°C ±2.16°F	-65 to 280°C -85 to 536°F
Ohms	Direct resistance or Potentiometer	n/a	n/a	0-4000 ohms	30 ohms	±0.4 ohms	n/a
T/C	J	n/a	n/a	-180 to 770°C -292 to 1418°F	35°C 63°F	±0.28°C ±0.5°F	-210 to 770°C -346 to 1418°F
	K	n/a	n/a	-150 to 1372°C -238 to 2501.6°F	40°C 72°F	±0.3°C ±0.54°F	-270 to 1390°C -454 to 2534°F
	E	n/a	n/a	-170 to 1000°C -274 to 1832°F	35°C 63°F	±0.26°C ±0.47°F	-270 to 1013°C -454 to 1855.4°F
	T	n/a	n/a	-200 to 400°C -328 to 752°F	20°C 36°F	±0.24°C ±0.43°F	-270 to 407°C -454 to 764.6°F
	R	n/a	n/a	0 to 1768°C 32 to 3214.4°F	50°C 90°F	±0.71°C ±1.28°F	-50 to 1786°C -58 to 3246.8°F
	S	n/a	n/a	0 to 1768°C 32 to 3214.4°F	50°C 90°F	±0.71°C ±1.28°F	-50 to 1786°C -58 to 3246.8°F
	B	n/a	n/a	400 to 1820°C 752 to 3308°F	75°C 135°F	±0.43°C ±0.77°F	200 to 1836°C 392 to 3336.8°F
	N	n/a	n/a	-130 to 1300°C -202 to 2372°F	45°C 81°F	±1.33°C ±2.39°F	-270 to 1316°C -454 to 2400.8°F
	C	n/a	n/a	0 to 2315°C 32 to 4199°F	100°C 180°F	±1.16°C ±2.09°F	0 to 2338°C 32 to 4240.4°F
Millivolts	DC	n/a	n/a	-50 to 1000mV	4mV	±0.04mV	-50 to 1000mV

* α values with both 32 and 128-point linearization curves are available. (Lower resolution values provided for compatibility with older units.)

Figure 5. Dimensions of the TDY HP housing with mounting flanges.

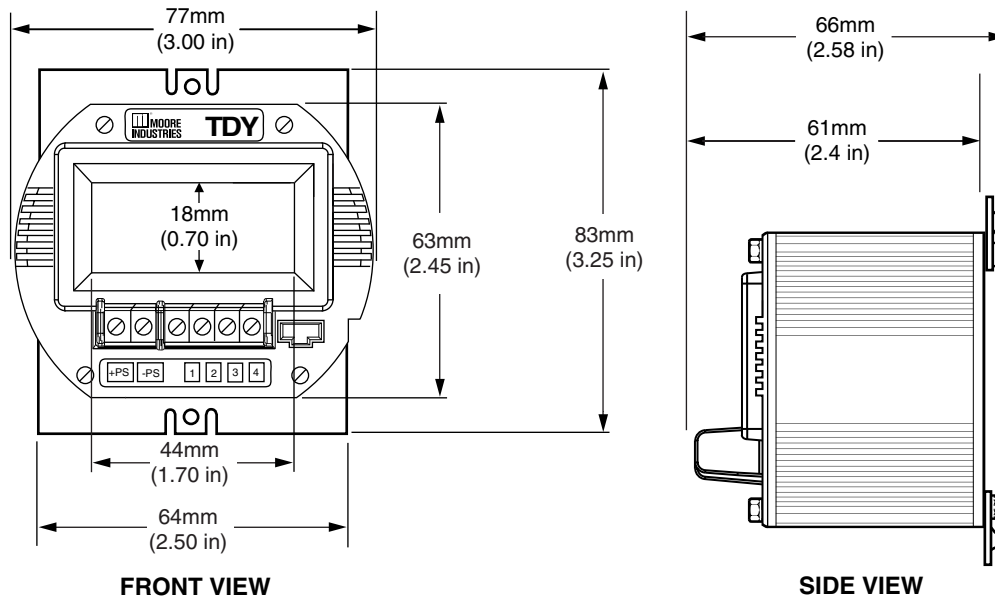
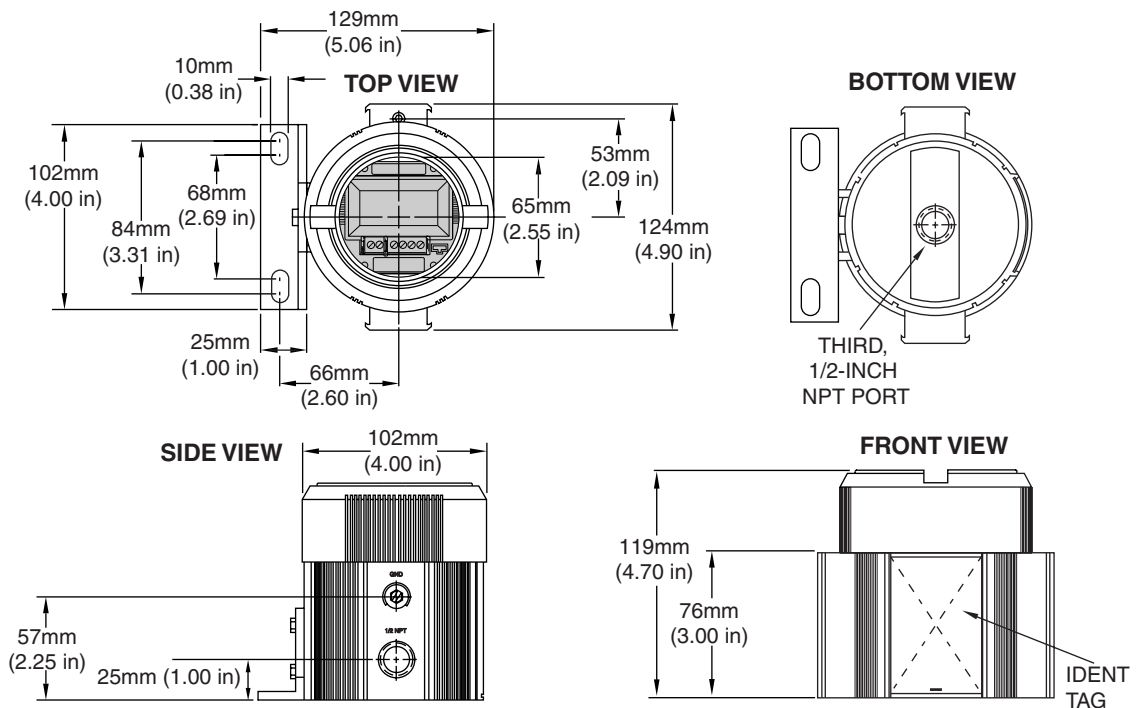

Figure 6. Dimensions of the TDY with the BH explosion-proof enclosure.



TDY

PC-Programmable Temperature Transmitter With Display

Figure 7. Dimensions of the TDY D-Box housing.

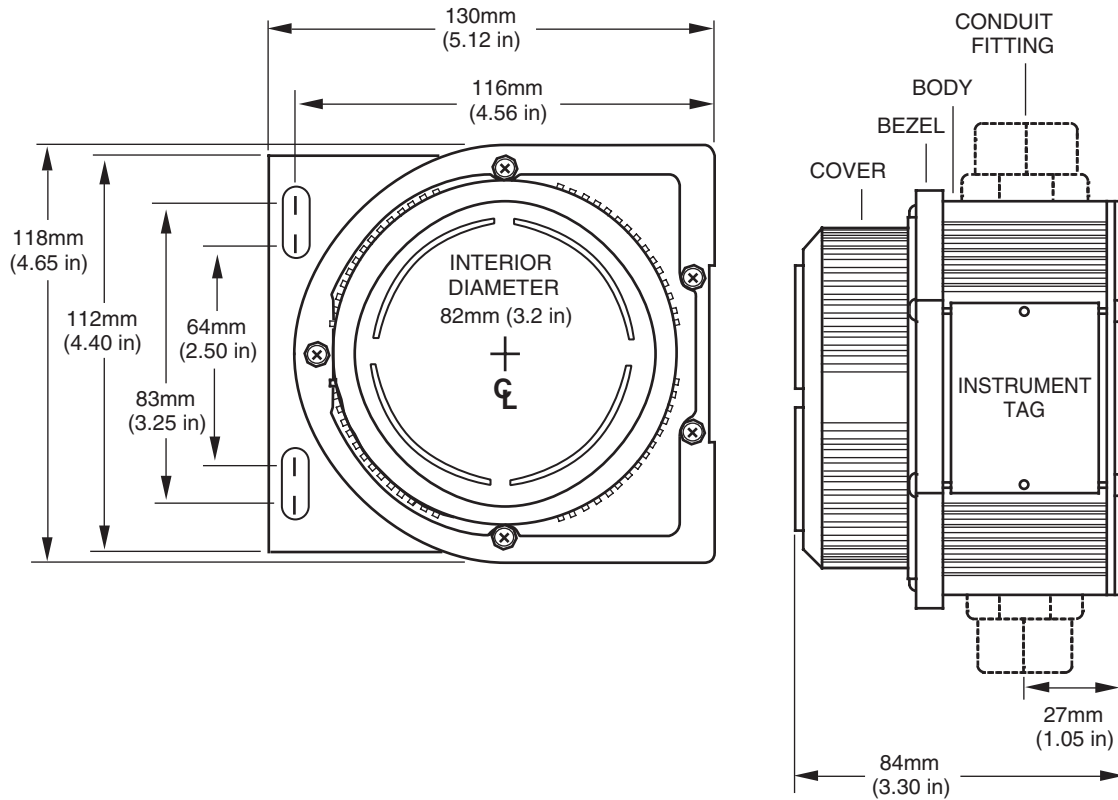
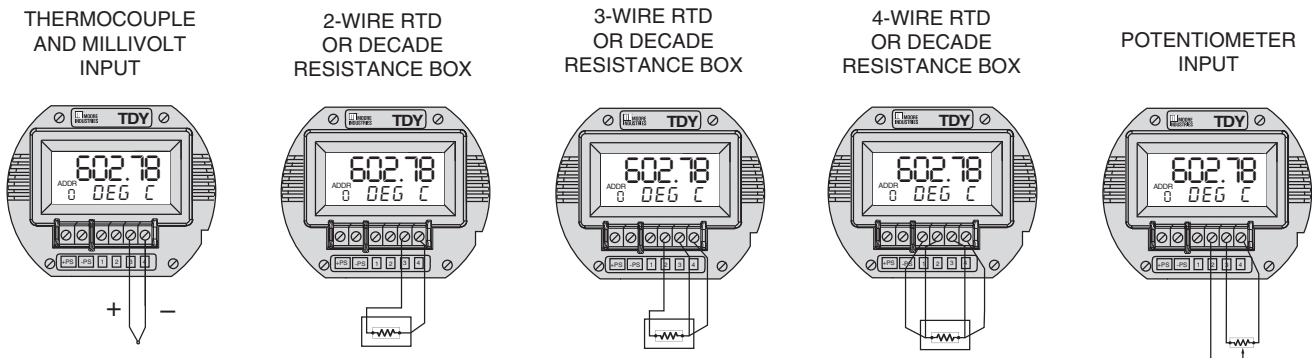

Figure 8. Sensor connections for the TDY.



United States • info@miinet.com
Tel: (818) 894-7111 • FAX: (818) 891-2816
Australia • sales@mooreind.com.au
Tel: (02) 8536-7200 • FAX: (02) 9525-7296

Demand Moore Reliability

www.miinet.com

BeNeLux • info@mooreind.eu
Tel: 03/448.10.18 • FAX: 03/440.17.97

China • sales@mooreind.sh.cn
Tel: 86-21-62491499 • FAX: 86-21-62490635
United Kingdom • sales@mooreind.com
Tel: 01293 514488 • FAX: 01293 536852